

DanMAX

The materials science beamline at MAX IV

DanMAX



Ministry of Higher Education
and Science



Region
Hovedstaden



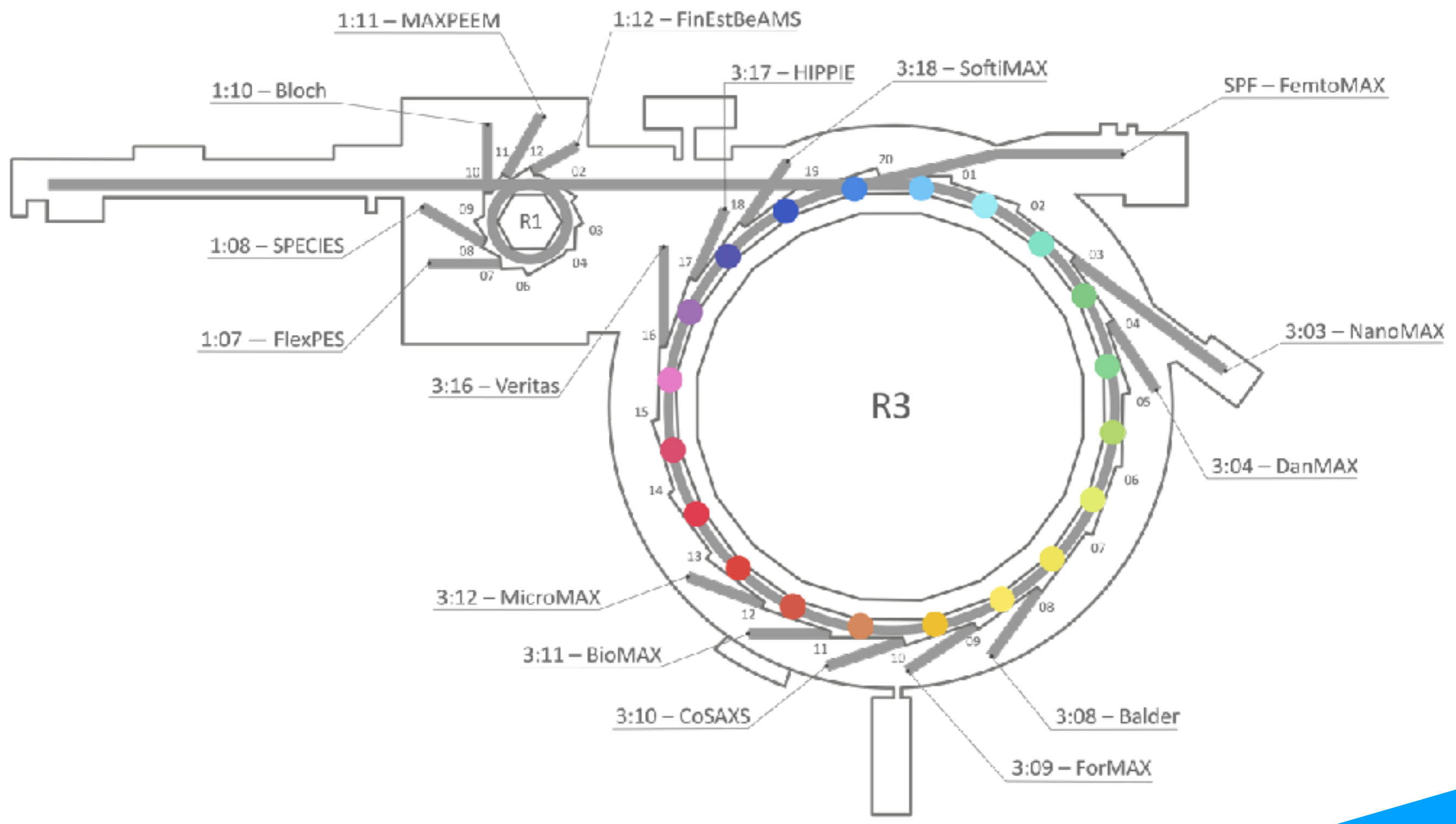

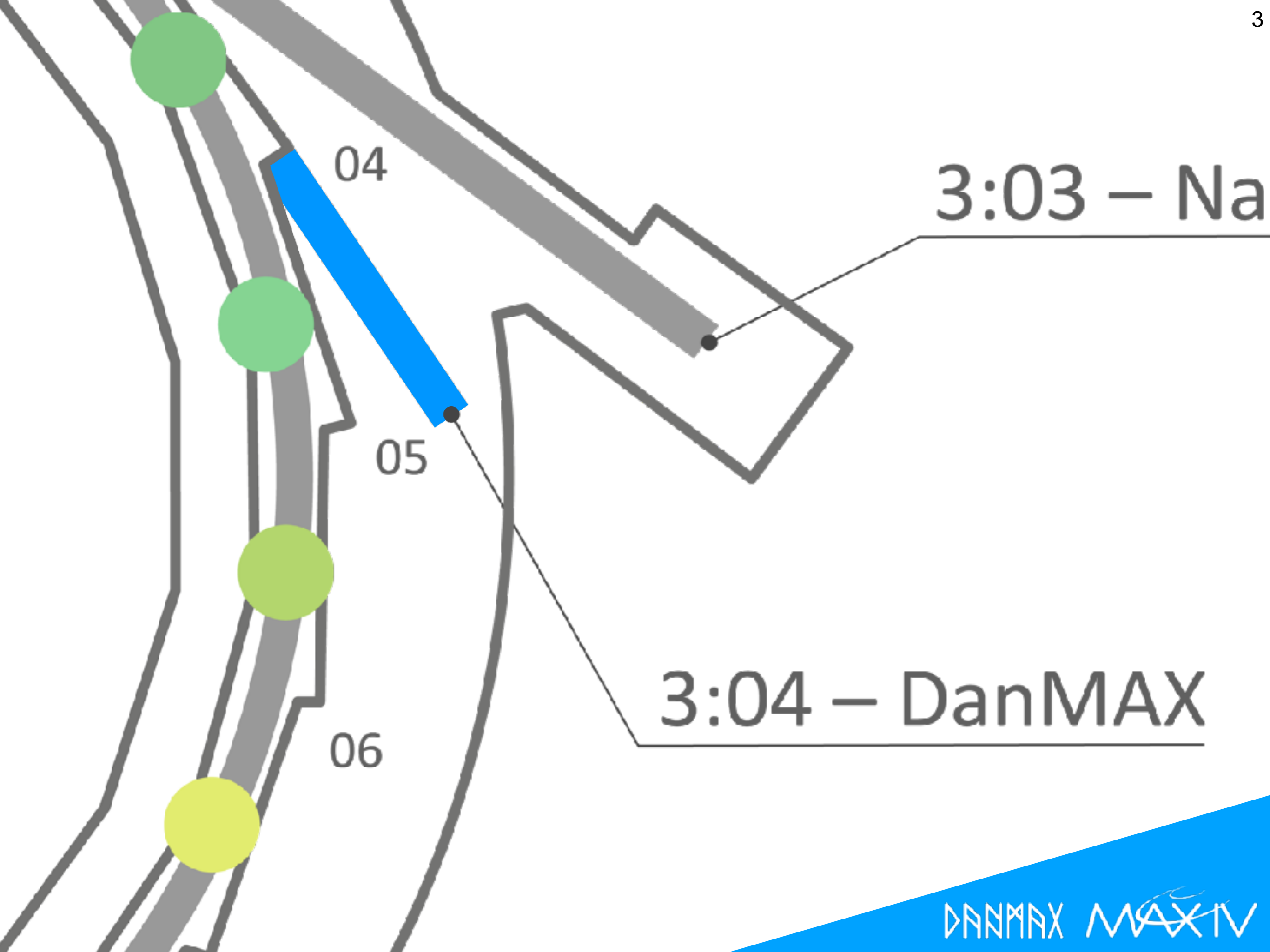

04

3:03 - Na

05

3:04 - DanMAX

06

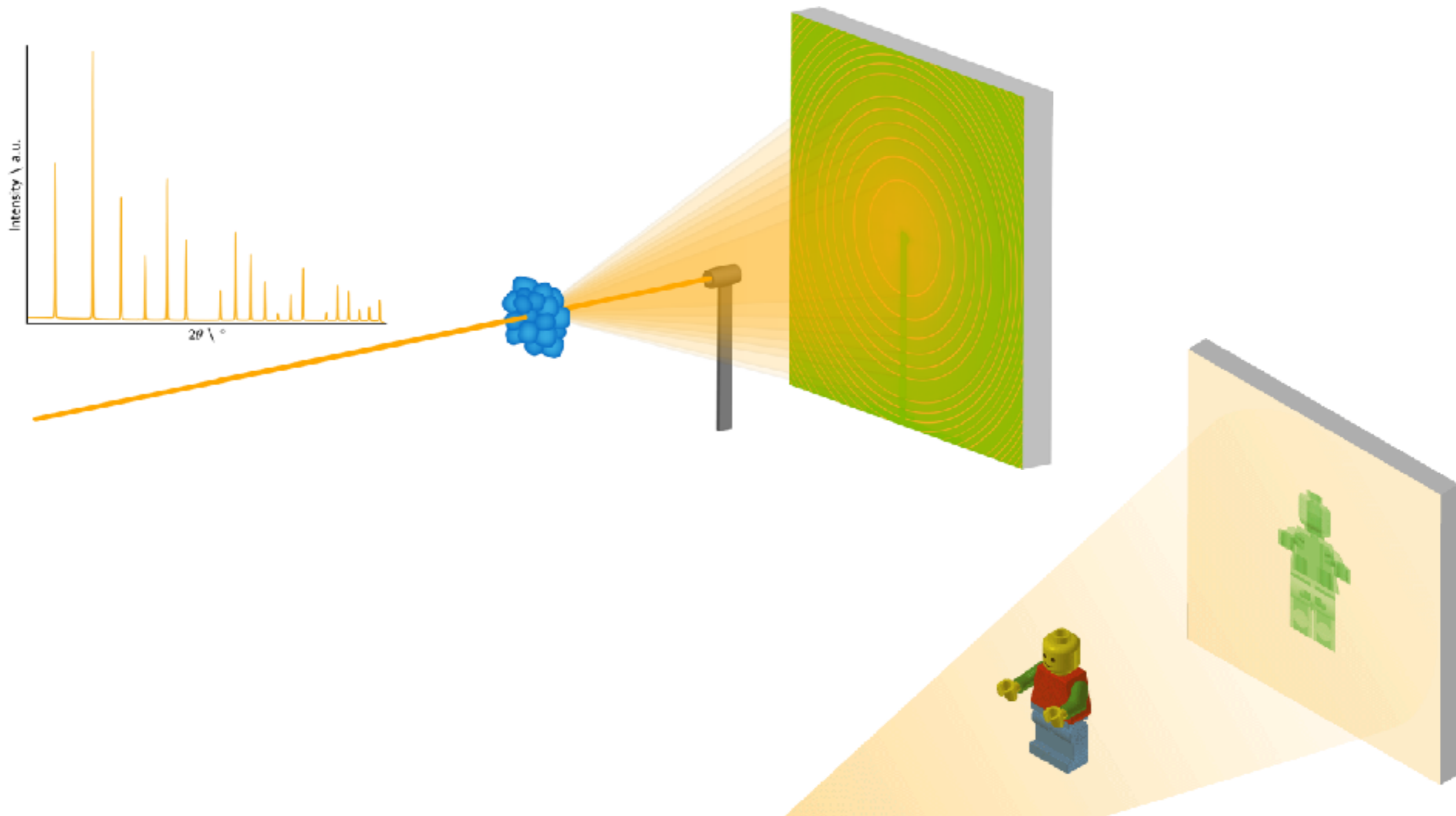

DanMAX: *Real* materials studied under *realistic* conditions at *realistic* time scales

Science @ DanMAX

Operando Battery Research

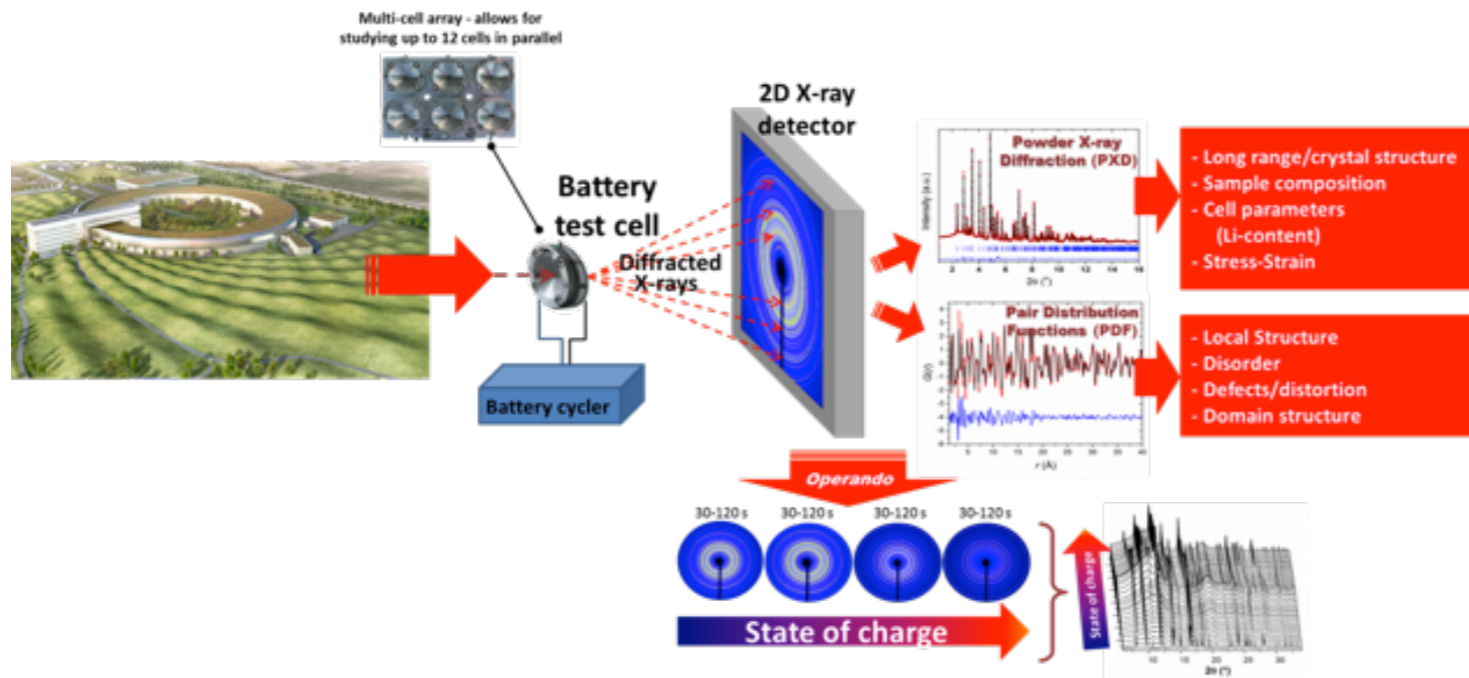

Nanocrystal Formation and Growth

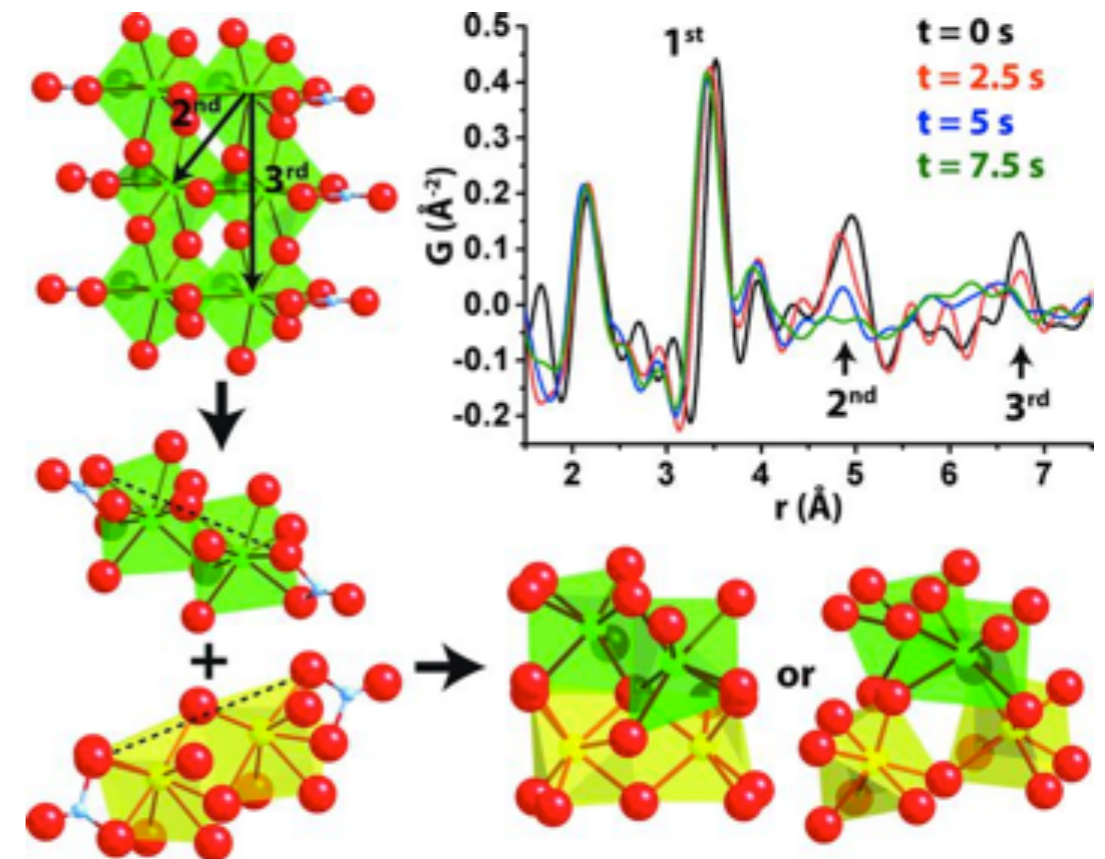

Pharmaceutical Materials Science

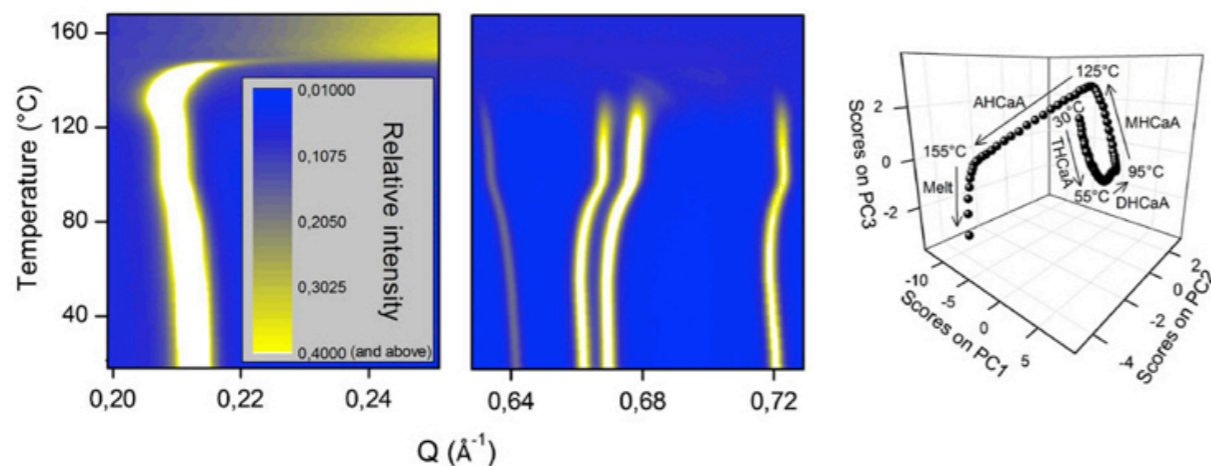

Science @ DanMAX

Composite Materials for Wind Turbine Blades

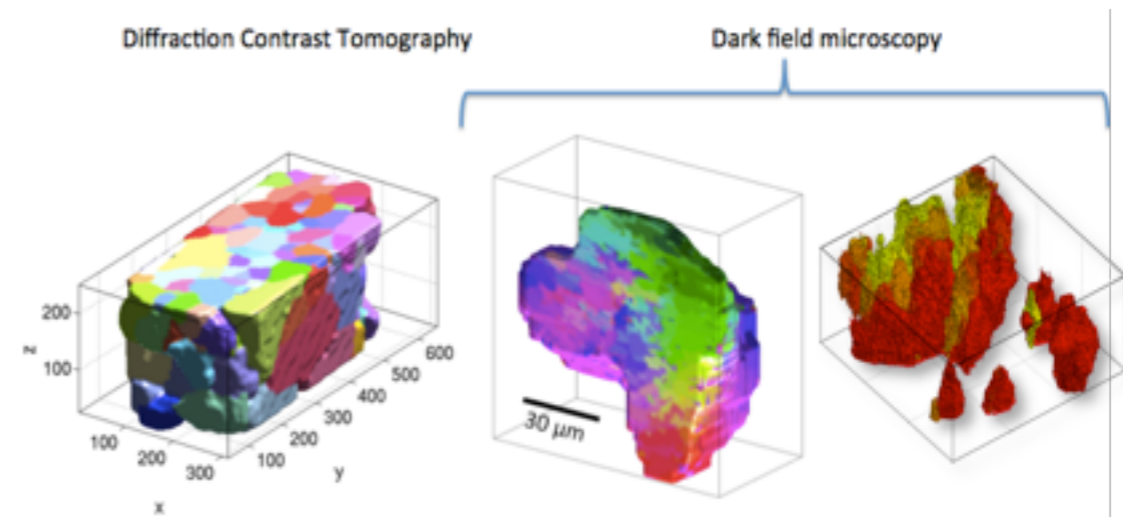
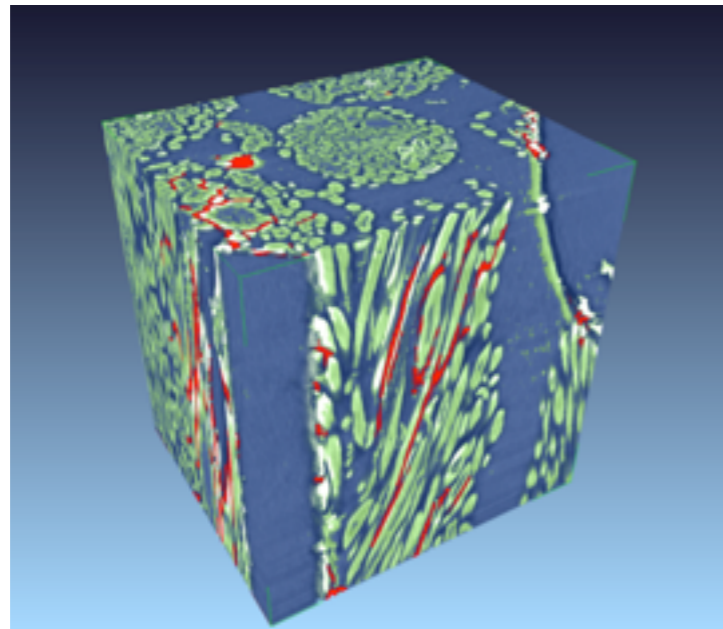

Oil Extraction and Natural Materials Science

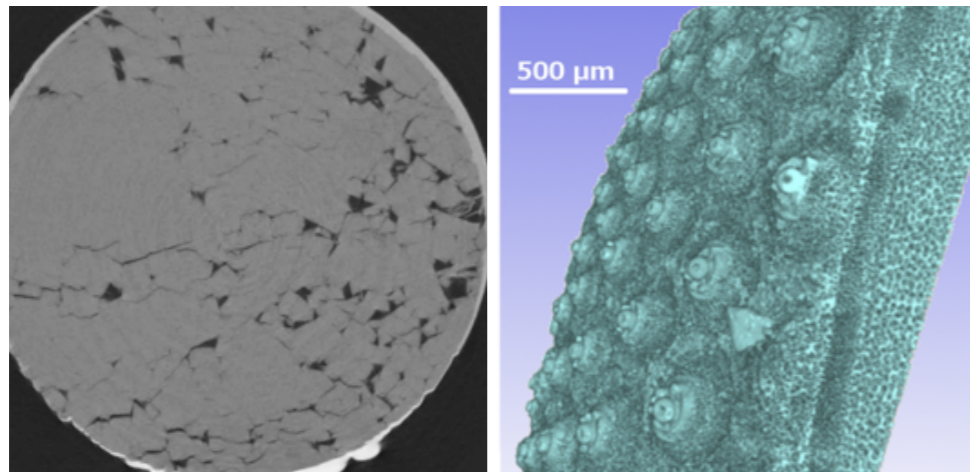

3D Domain Evolution and Multiscale Studies of Polycrystalline Materials

Science @ DanMAX

Biological and bio-inspired materials

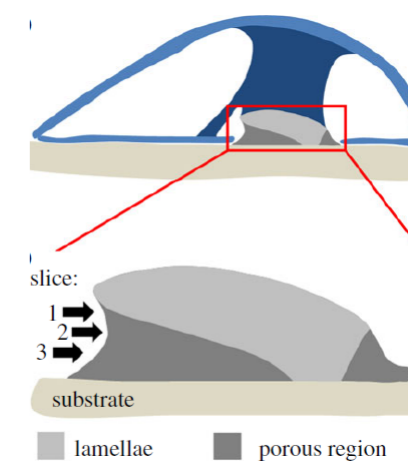
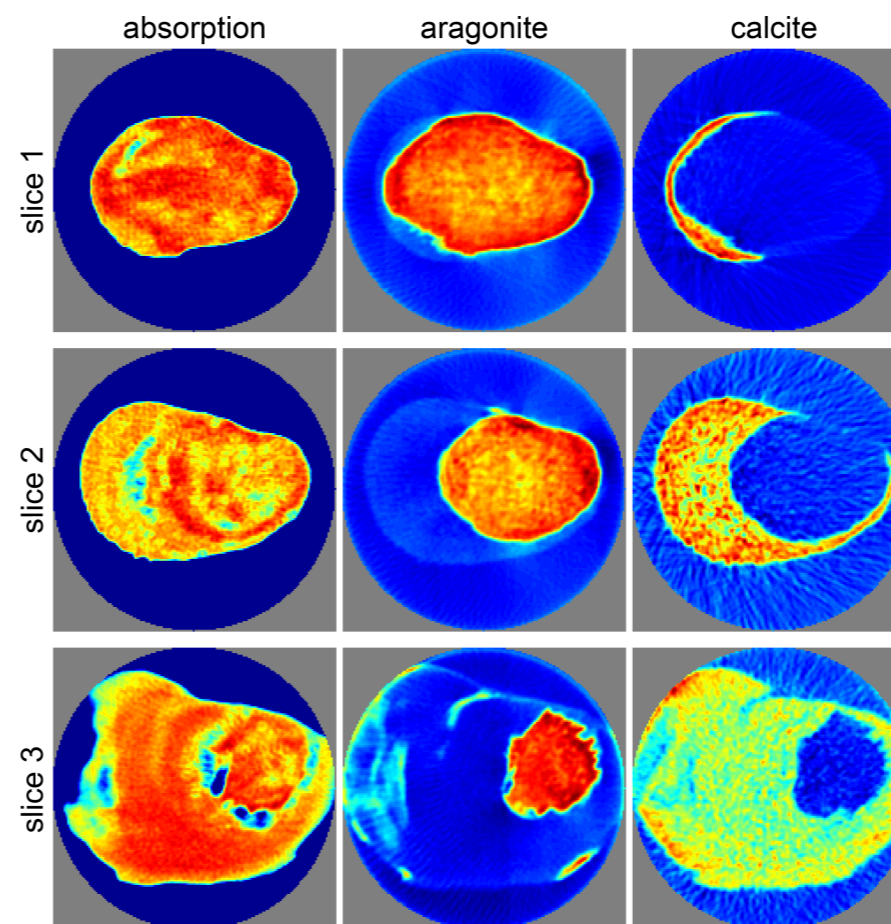
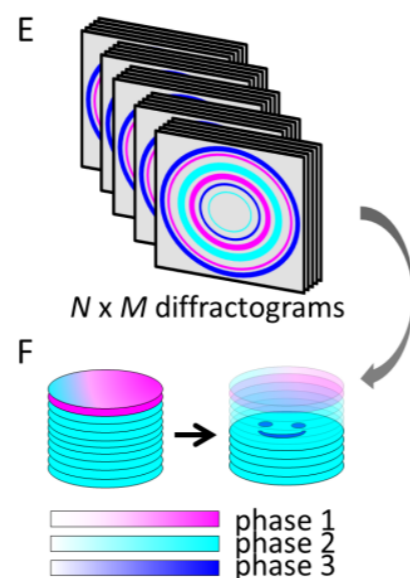
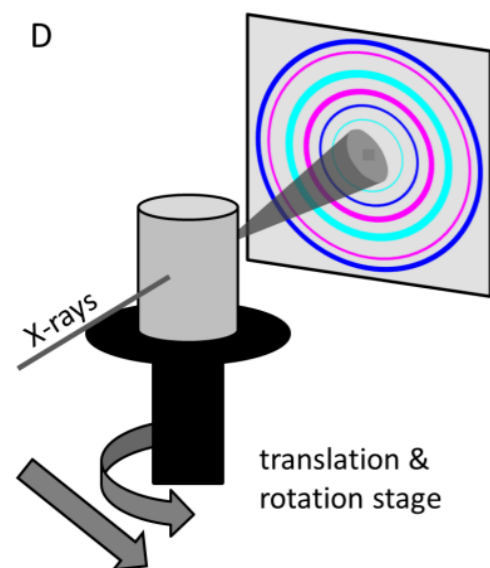

DanMAX

Layout, hardware, and upcoming procurements



Beamline layout



End station layout

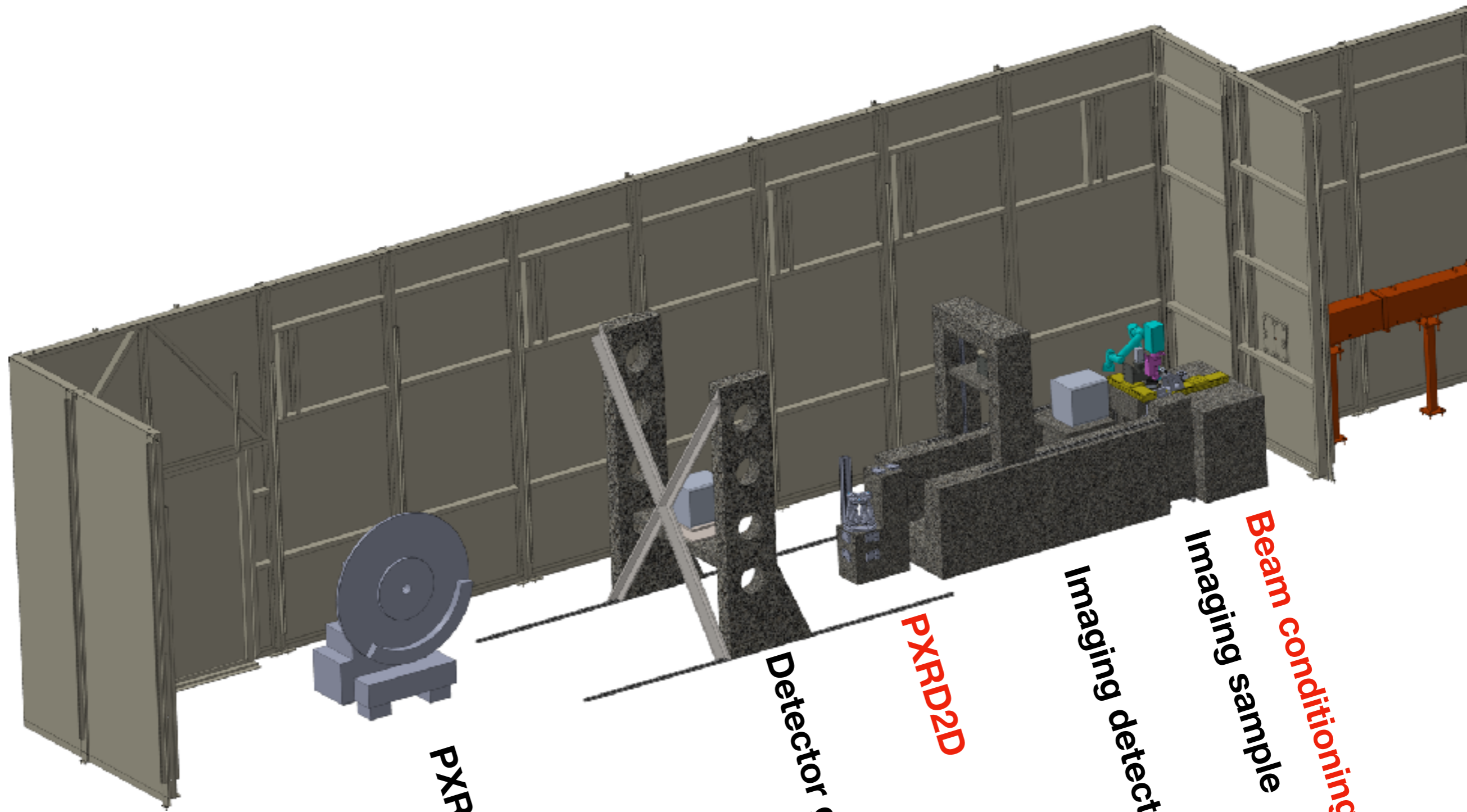

PXRD1D: HERD

Detector gantry

PXRD2D

Imaging detector

Imaging sample

Beam conditioning

Beam conditioning unit and PXRD 2D

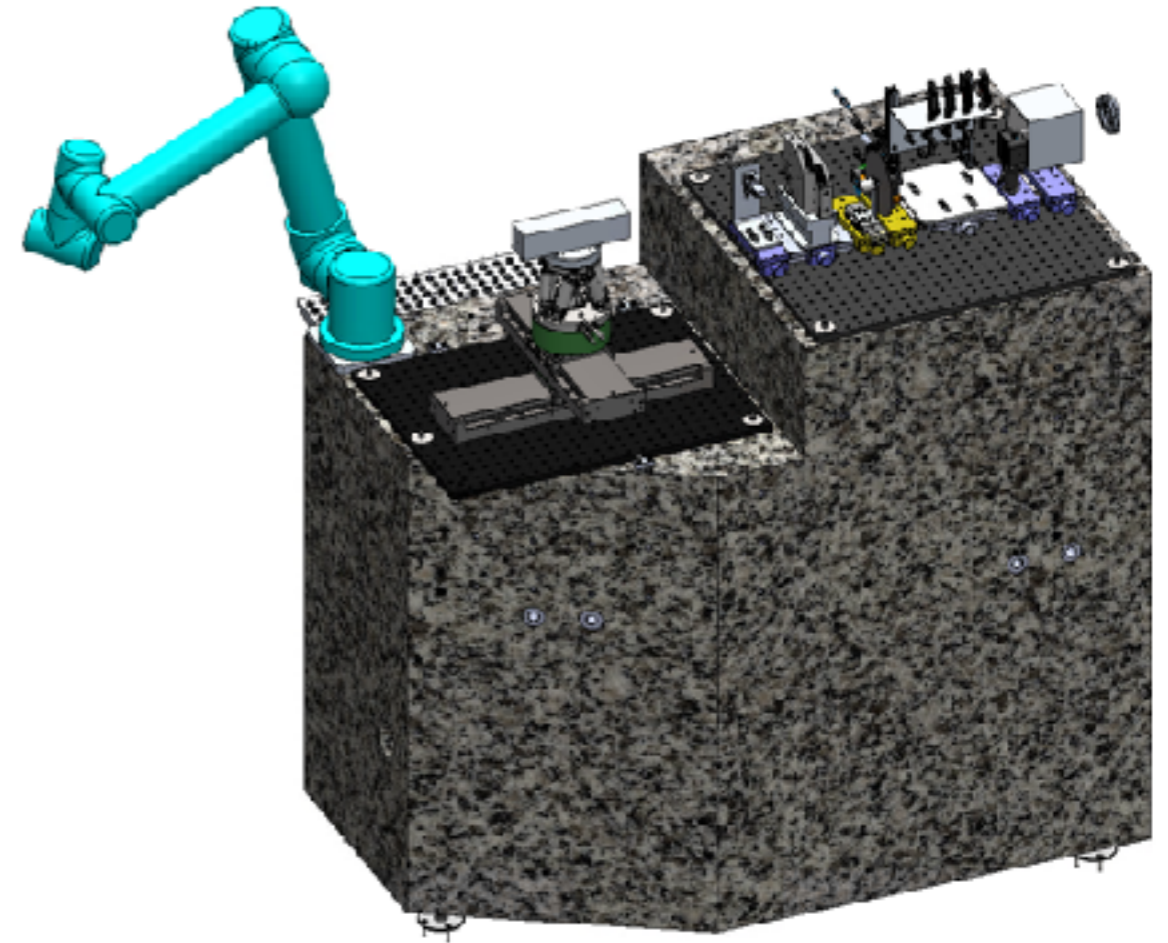
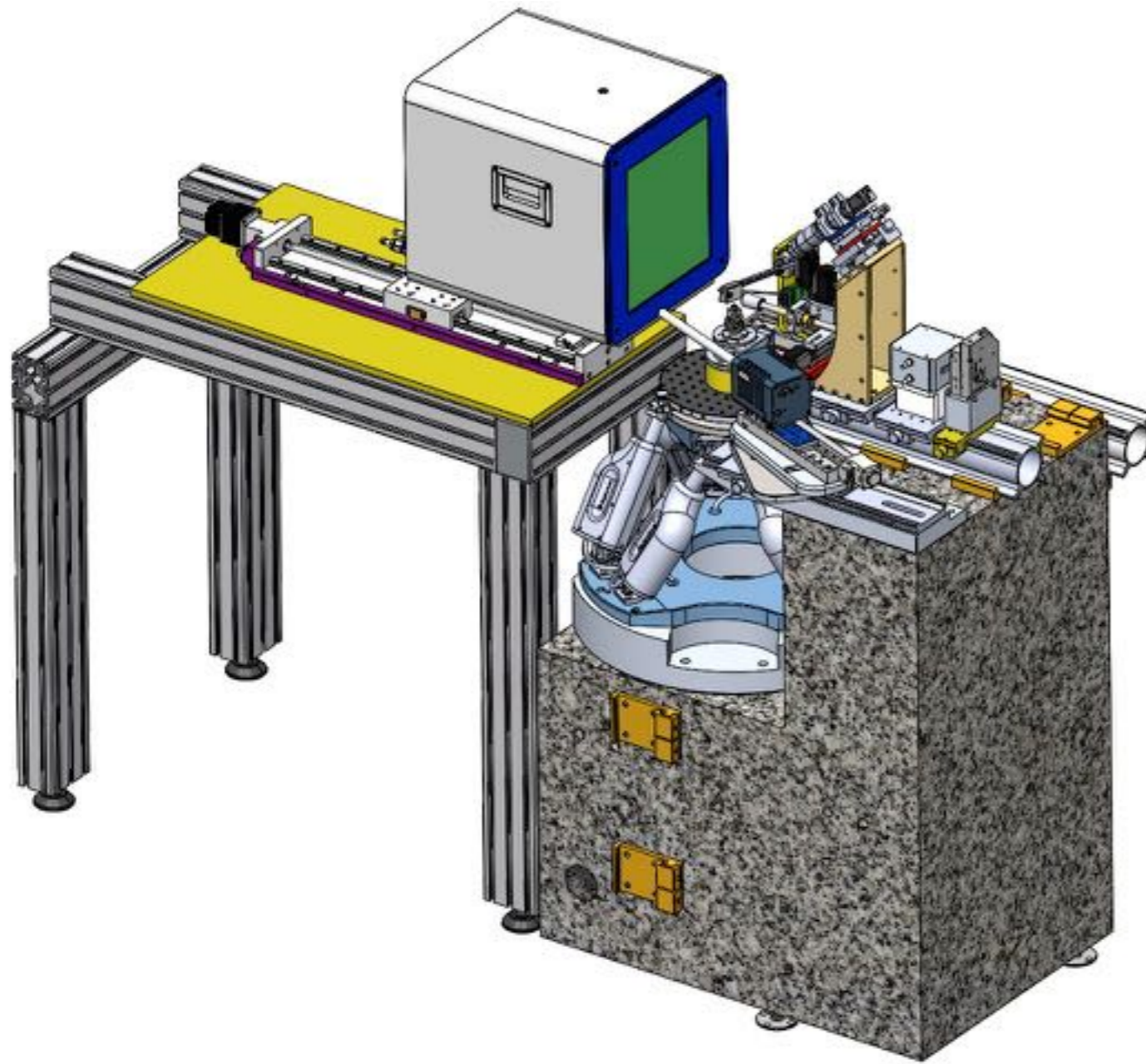

End station - Imaging

Imaging sample stage and
imaging detector stage:
Procurement Q1 2020



<https://www.physikinstrumente.com>



<http://www.optiquepeter.com>

Detector gantry



Detector gantry:
Procurement Q1 2020

HERD - High Enough Resolution Diffractometer...



Goniometer:
Procurement Q3-4 2020

Sample environments

- Cold & hot N₂ gas blower (90 K - 1000 K)
- Chemical reactors:
 - High temperature - high temperature stability - high pressure
- Robotic sample changer
- Gas flow with various gases and humidity + MS
- Multi-AMPIX battery setup with potentiostat
- XYZ-R_z stage with sub- μ m precision
- High pressure cells (DAC) with online off-axis Raman setup
- X-ray fluorescence detector for elemental mapping
- Vacuum sample chamber
- Mechanical manipulators (stress/strain/sheer...)
- ...



oxcryo.com

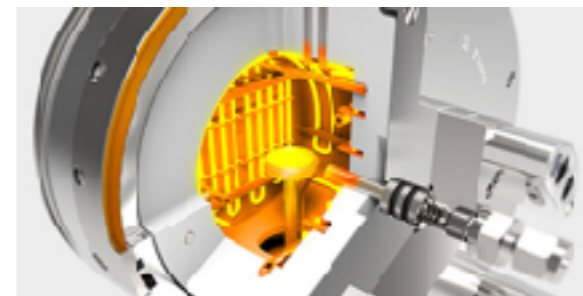

anton-paar.com

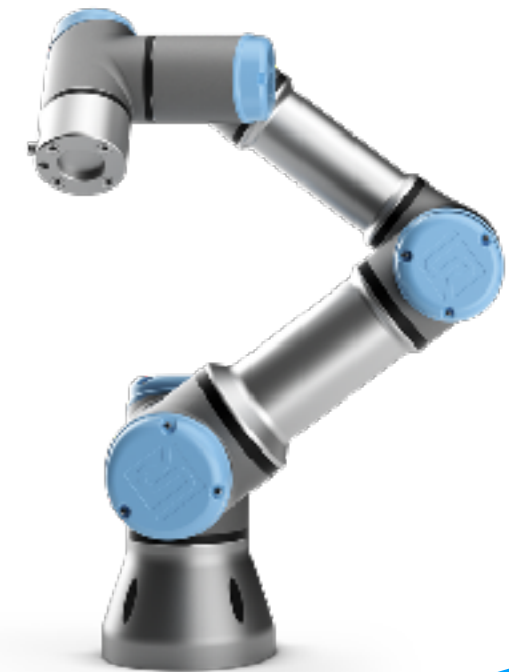

universal-robots.com

Sample environments

- Cold & hot N₂ gas blower (90 K - 1000 K)
- **Chemical reactors:**
 - High temperature - high temperature stability - high pressure
- Robotic sample changer
- Gas flow with various gases and humidity + MS
- **Multi-AMPIX battery setup with potentiostat**
- XYZ-R_z stage with sub- μ m precision
- **High pressure cells (DAC)** with online off-axis Raman setup
- **X-ray fluorescence detector for elemental mapping**
- **Vacuum sample chamber**
- Mechanical manipulators (stress/strain/shear...)
- ...



oxcryo.com



anton-paar.com

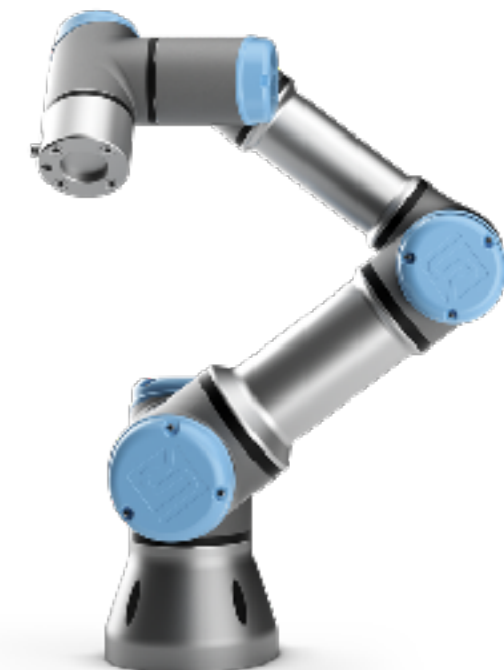

universal-robots.com

One more thing...



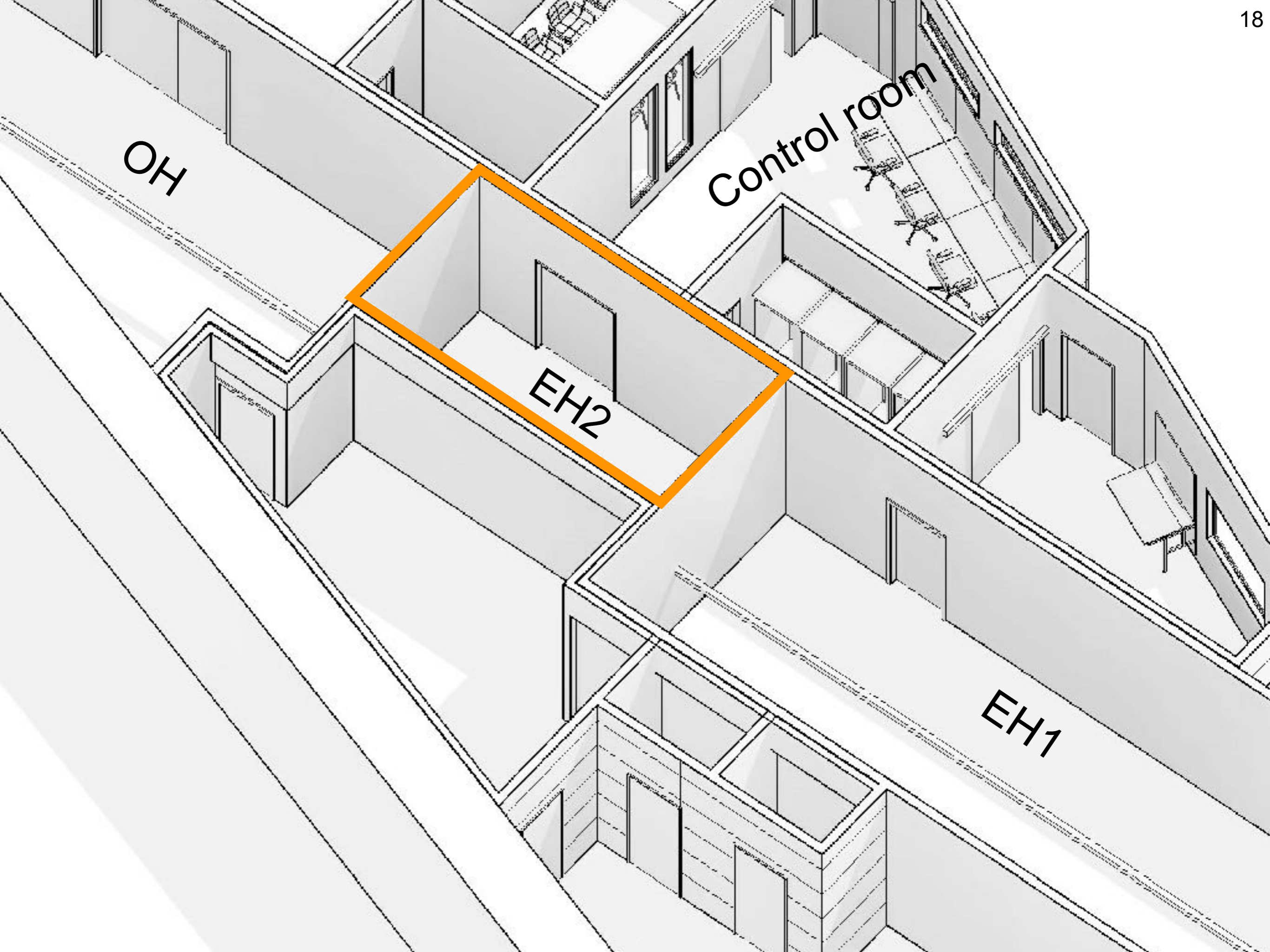

OH

Control room

EH2

EH1

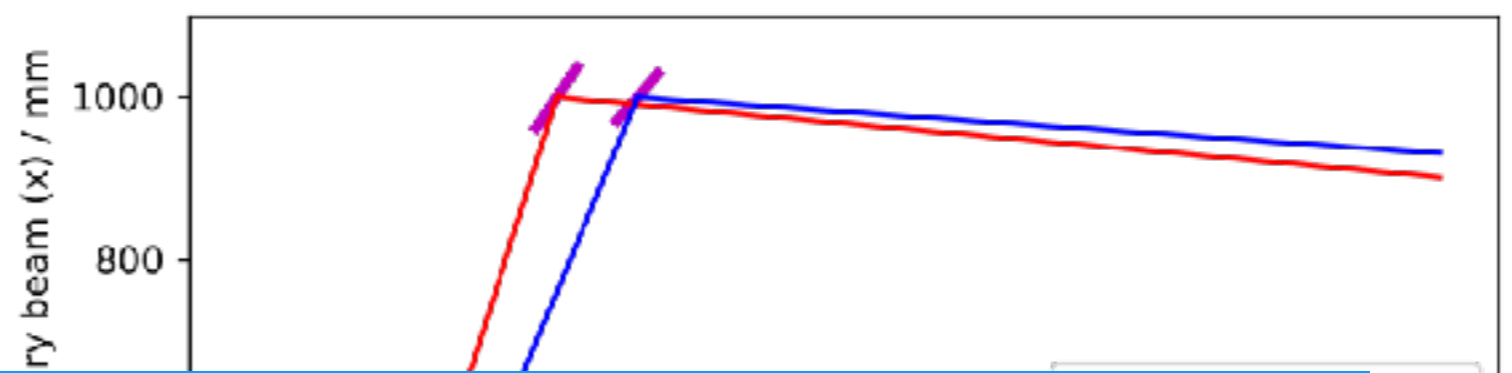

X-ray optics
Optical tables
End station instrumentation
Detector(s)
Sample environments





Ministry of Higher Education
and Science



Region
Hovedstaden

midt
regionmidtjylland

DTU



AARHUS
UNIVERSITY



UNIVERSITY OF
COPENHAGEN

MAXIV
LABORATORY



maxiv.lu.se/danmax



[@DanMAX_MAXIV](https://twitter.com/DanMAX_MAXIV)

Mads Ry Jørgensen: mads@chem.au.dk

Innokenty Kantor: inkan@fysik.dtu.dk